

# C830

Universal Process Converter-Transmitter



Operator Manual

Cod.Prod. C830\_UK\_M1

English Language

Product Rev: 1.0 - Manual Rev: 1.2



**Dear Customer**

**We thank you for choosing our product, which we hope will be in line with your expectations, because our mission is not to handle or manage simply things that perform a technical function but we work hard every day to create something more complete than conceptually, is more a casket that contains so many things, our ideas, our ability to do, our entrepreneurial commitment to be able to contribute to the construction of a new world, even with only one brick, and all this because we are convinced that businesses like ours have a fundamental social role in building a sustainable tomorrow.**

**We are also ambitious and we like to hope that our work in all its forms can contribute even in its small to your success.**

**Finally, we emphasize that while working daily for continuous improvement, we are not perfect and unfortunately we may have something escaped.**

**If you notice something minimal and apparently irrelevant, or even if you have suggestions, please report it promptly, however, with an email to [info@ceamgroup.it](mailto:info@ceamgroup.it)**

**Sincere and constructive customer feed-back is a very important resource for us, and a concrete help to improve.**

**Thank you**

**Simone Campinoti  
President**



## Warning Symbol

This document contains notices that you should observe to ensure your own personal safety, as well as to protect the product and connected equipment. These notices are highlighted in the manual by a warning triangle and are marked as follows.



The danger symbol indicates that death or severe personal injury may result if proper precautions are not taken. Do not proceed beyond a warning symbol until the indicated conditions are fully understood and met.

## Preface

Original equipment manufacturer reserves the right to change information available in this document without notice. The manufacturer is not liable for any damages incurred to equipment/personal during installation or use of equipment as explained in this document. User must acquire sufficient knowledge & skills prior to using equipment in the application and follow all the local standards & regulations to meet safety requirements.

## Copyright

The documentation and the software included with this product are copyrighted 2018 by Brainchild Electronic Co. Ltd. All rights are reserved. Brainchild Electronic Co., Ltd. reserves the right to make improvements in the products described in this manual at any time without notice.

No part of this manual may be reproduced/copied/translated or transmitted in any form or by any means without the prior written permission of Brainchild Electronic Co., Ltd. The information we supply is believed to be accurate and reliable as of this printing. However, we assume no responsibility for its use.

## Contact Information

**CEAM Control Equipment srl**  
Via Val D'Orme 291  
50053 Empoli (Firenze) Italy  
Phone (+39) 0571 924181  
Fax (+39) 0571 924505  
Email (General) [info@ceamgroup.it](mailto:info@ceamgroup.it)  
Web [www.ceamgroup.com](http://www.ceamgroup.com)  
Store Online [www.sensorstore.it](http://www.sensorstore.it)  
Support [www.ceamsupport.it](http://www.ceamsupport.it)

# TABLE OF CONTENTS

<b>1</b>	<b>INTRODUCTION</b>	<b>9</b>
1.1	Introduction	9
1.2	Features	9
1.3	Specifications	11
1.4	Ordering Code	13
1.4.1	Accessories	13
1.4.2	Related Products	13
1.5	Programming Port	13
1.6	Display Board Keys	14
1.7	Menu Flowchart	15
1.7.1	Basic Menu	15
1.7.2	Output Menu (oUt)	16
1.7.3	Communication Menu (CoMM)	17
1.7.4	Manual Mode Menu	18
1.7.5	Calibration Mode	19
1.8	Parameter Availability Table	19
1.9	Parameters Description	21
<b>2</b>	<b>INSTALLATION AND WIRING</b>	<b>27</b>
2.1	Unpacking	27
2.2	Dimension	28
2.3	Wiring	29
2.3.1	Terminal Connection	29
2.3.2	Power Wiring	29
2.3.3	Sensor Installation	30
2.3.4	Input Wiring	30
2.3.5	Retransmission Output Wiring	31
2.3.5.1	Output 1	31
2.3.5.2	Output 2	31
2.3.5.3	Output 3	32
2.3.6	Digital Input Wiring	32
2.3.7	RS-485 Data Communication	33
<b>3</b>	<b>PROGRAMMING</b>	<b>34</b>
3.1	User Security	34
3.2	Calibration Password	34
3.3	Signal Input	34
3.4	Output Type	35
3.5	Retransmission	35
3.6	Zero and Span adjustment	35
3.7	Square Root function (SQRT)	35
3.8	User Calibration	36
3.9	Digital Filter	36
3.10	Manual Control	37
3.11	Factory Default	37
3.12	Data Communication	37
3.12.1	RS-485 Setup	37
3.13	Digital Input	37
3.13.1	Digital Input Functions	38

<b>4</b>	<b>CALIBRATION</b>	<b>39</b>
<b>4.1</b>	<b>Equipment Required Before Calibration</b>	<b>39</b>
4.1.1	Manual Calibration Procedure	39
4.1.1.1	Calibrate Zero of A to D Converter	39
4.1.1.2	Calibrate Gain of A to D Converter	39
4.1.1.3	Calibrate RTD Input	39
4.1.1.4	Calibrate Offset of Cold Junction Compensation	40
4.1.1.5	Calibrate Gain of Cold Junction Compensation	40
4.1.1.6	Calibrate Linear Input	40
<b>5</b>	<b>COMMUNICATION</b>	<b>42</b>
<b>5.1</b>	<b>Functions Supported</b>	<b>42</b>
5.1.1	Function Code 03: Read Holding Registers	42
5.1.2	Function Code 06: Preset Single Register	42
5.1.3	Function Code 16: Preset Multiple Register	43
<b>5.2</b>	<b>Exception Responses</b>	<b>43</b>
<b>5.3</b>	<b>Parameter Mapping</b>	<b>44</b>
<b>5.4</b>	<b>Error Code</b>	<b>44</b>
<b>5.5</b>	<b>Mode</b>	<b>44</b>
<b>5.6</b>	<b>PROG Code</b>	<b>44</b>
<b>5.7</b>	<b>Scaling</b>	<b>45</b>
<b>5.8</b>	<b>Data Conversion</b>	<b>45</b>
<b>5.9</b>	<b>Communication Examples</b>	<b>45</b>
5.9.1	Read PV, MV1, MV2 and MV3	45
5.9.2	Perform Reset Function (same effect as pressing R key)	45
5.9.3	Enter Auto Tuning Mode	45
5.9.4	Enter Manual Control Mode	45
5.9.5	Read All Parameters	46
5.9.6	Modify Calibration Co-efficient	46

## TABLE OF TABLES

2-1. ENVIRONMENTAL SPECIFICATION .....	27
5-1. FUNCTION CODE 03 .....	42
5-2. FUNCTION CODE 06 .....	42
5-3. FUNCTION CODE 16 .....	43
5-4. EXCEPTION CODE .....	43
5-5. ERROR CODE .....	44
5-6. OPERATION MODE .....	44
5-7. PROGRAM CODE .....	44
5-8. SCALING FOR INLO, INHI, PV, ANL1, ANL2, ANL3, ANH1, ANH2 AND ANH3 .....	45

## TABLE OF FIGURES

1-1. PROGRAMMING PORT .....	10
1-2. RSC FRONT PANEL .....	14
1-3. HOW CHARACTER ARE DISPLAYED ON THE LCD SCREEN .....	14
2-1 DIMENSION .....	28
2-2 TERMINAL CONNECTION .....	29
2-3. POWER WIRING .....	30
2-4 INPUT WIRING .....	30
2-5 OUTPUT 1 LINEAR CURRENT .....	31
2-6 OUTPUT 1 LINEAR VOLTAGE .....	31
2-7 OUTPUT 2 LINEAR CURRENT .....	31
2-8 OUTPUT 2 LINEAR VOLTAGE .....	31
2-9 OUTPUT 3 LINEAR CURRENT .....	32
2-10 OUTPUT 3 LINEAR VOLTAGE .....	32
2-11 DIGITAL INPUT WIRING .....	32
2-12 RS-485 WIRING .....	33
3-1. CONVERSION CURVE FOR LINEAR TYPE PROCESS SIGNAL .....	35
3-2. TWO POINT USER CALIBRATION .....	36
3-3. FILTER CHARACTERISTICS .....	37
4-1. COLD JUNCTION CALIBRATION SETUP .....	40



# 1 Introduction

## 1.1 Introduction

The signal conditioner incorporates two bright easy to read LCD Displays which indicate Process Value (PV) and user selected parameter. It is powered by an 11-26 or 90-250 VDC /VAC supply. It is fully programmable for **Linear Voltage, Linear Current, PT100 and thermocouple types J, K, T, E, B, R, S, N, L, U, P, C, and D** input. The input signal is digitized by using an 18-bit A to D converter. Its fast sampling rate allows the signal conditioner to retransmit the signal faster. It can do a maximum of 3 retransmission with one input.

## 1.2 Features

The new generation of signal conditioner has a lot of unique features. The unique features are listed below.

- ❖ Optional LCD Display
- ❖ High Accuracy 18 Bit A-D Conversion
- ❖ Up to 3 retransmission outputs with 15 Bit resolution
- ❖ Fastest Sampling Rate of 200 msec
- ❖ Universal Input
- ❖ RS-485 Communication
- ❖ Event Input
- ❖ Lockout Protection
- ❖ Bidirectional Menu Navigation
- ❖ SQRT Function for PV

### LCD Display

This signal conditioner will be equipped with high brightness LCD Display.

### Digital Communication

RS-485 Digital communication is available as an additional option. These options allow the units to be integrated with supervisory control systems and software.

A Micro USB programming port is available for automatic configuration, calibration and testing without the need of access the keys on display board.

### High Accuracy

This signal conditioner is manufactured using an innovative technology which contains an 18-bit A to D converter for high-resolution measurement (true 0.1°F resolution for thermocouple and PT100 sensors) and a 15-bit D to A converter for a linear current or voltage control output. The innovative technology provides improved operating performance, enhanced reliability and higher density with low cost.

### Fast Sampling Rate

The sampling rate of the input A to D converter reaches 200 msec. This fast sampling rate allows the signal conditioner to retransmit faster.

### Digital Communication

The controllers can be equipped with an optional RS-485 interface to provide digital communication. By using twisted pair wires, up to 247 units can be connected together via an RS-485 interface to a host computer.

## Programming Port

A Micro USB programming port is available for automatic configuration, calibration and firmware upgrades without the need to access the keys on the front panel.

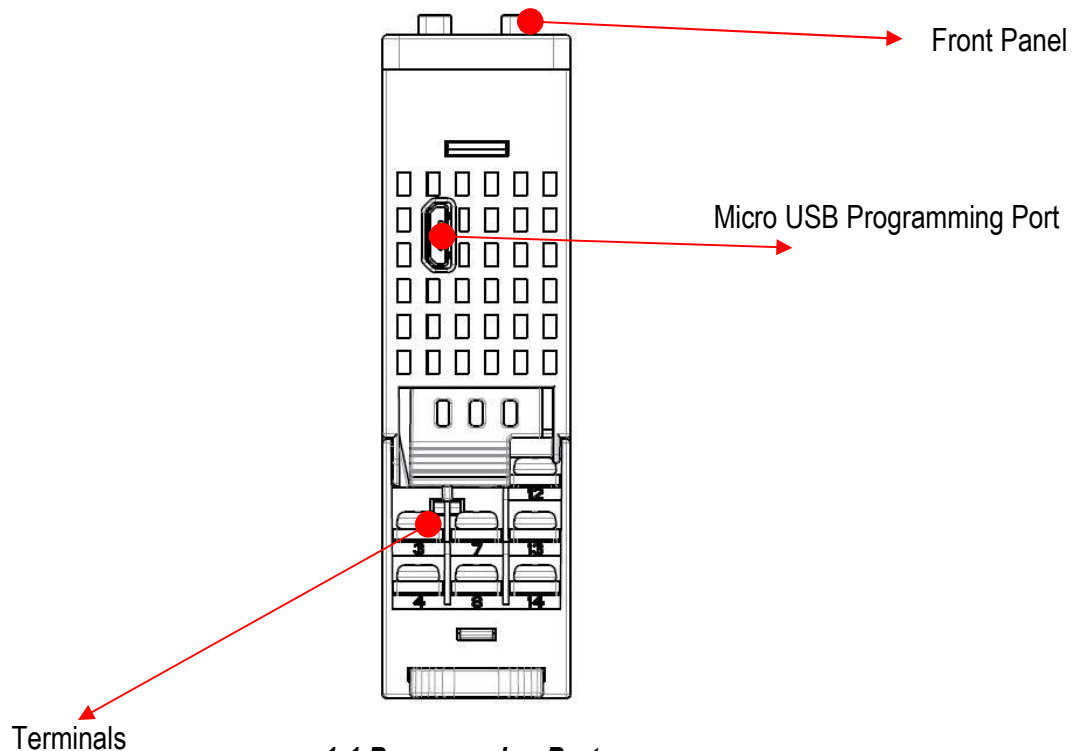

## Lockout Protection

According to user security requirements, one of four lockout levels (NONE, ALL, USER, SET) can be selected to prevent certain settings from being changed.

## Digital Filter

A first-order low-pass filter with a programmable time constant is used to improve the stability of the process value (PV). This is particularly useful in certain applications where the process value is too unstable to be read.



## Event Input

Event Input is available as an option to change certain function.

## Analog Retransmission

This signal conditioner can do a maximum of 3 Analog retransmission with one input.

## Bidirectional Menu Navigation

This controller has bidirectional menu navigation. This will allow the user to access previous menu settings easily by using   keys.

## SQRT Function

The signal conditioner is having PV SQRT function

### 1.3 Specifications

Specification	RSC			
Power Supply	90 to 250VAC, 47 to 63Hz, 20 to 28 VAC, 47-63Hz / 11 to 40 VDC			
Power Consumption	10VA, 5W Maximum			
<b>Signal Input</b>				
Type	Thermocouple (J, K, T, E, B, R, S, N, L, U, P, C, D), RTD(PT100(DIN), PT100(JIS)), Current(mA), Voltage(V)			
Resolution	18 Bits			
Sampling Rate	5 Times / Second (200msec)			
Maximum Rating	-2VDC minimum, 12VDC maximum			
Input Characteristics	<b>Type</b>	<b>Range</b>	<b>Accuracy @ 25°C</b>	<b>Input Impedance</b>
	J	-120°C to 1000°C ( -184°F to 1832°F)	±2°C	2.2 MΩ
	K	-200°C to 1370°C (-328°F to 2498°F)	±2°C	2.2 MΩ
	T	-250°C to 400°C ( -418°F to 752°F)	±2°C	2.2 MΩ
	E	-100°C to 900°C ( -148°F to 1652°F)	±2°C	2.2 MΩ
	B	0°C to 1820°C (32°F to 3308°F)	±2°C (200°C to 1800°C)	2.2 MΩ
	R	0°C to 1767.8°C (32°F to 3214°F)	±2°C	2.2 MΩ
	S	0°C to 1767.8°C (32°F to 3214°F)	±2°C	2.2 MΩ
	N	-250°C to 1300°C (-418°F to 2372°F)	±2°C	2.2 MΩ
	L	-200°C to 900°C ( -328°F to 1652°F)	±2°C	2.2 MΩ
	U	-200°C to 600°C (-328°F to 1112°F)	±2°C	2.2 MΩ
	P	0°C to 1395°C (32°F to 2543°F)	±2°C	2.2 MΩ
	C	0°C to 2300°C (32°F to 4172°F)	±2°C	2.2 MΩ
	D	0°C to 2300°C (32°F to 4172°F)	±2°C	2.2 MΩ
	PT100(DIN)	-200°C to 850°C (-328°F to 1562°F)	±0.4°C	1.3KΩ
	PT100(JIS)	-200°C to 600°C ( -328°F to 1112°F)	±0.4°C	1.3KΩ
mA	-3mA to 27mA	±0.05%	2.5Ω	
VDC	-1.3VDC to 11.5VDC	±0.05%	1.5MΩ	
Temperature Effect	1.5μV /°C for all inputs except mA input, 3.0μV /°C for mA			
Sensor Lead Resistance Effect	<b>Thermocouple:</b> 0.2 μV /°Ω; <b>3-wire RTD:</b> 2.6°C /Ω of Difference of Resistance of two leads <b>2-wire RTD:</b> 2.6°C /Ω of Sum of Resistance of two leads			
Burn-out Current	200nA			
Common Mode Rejection Ratio (CMRR)	120 dB			
Normal Mode Rejection Ratio (NMRR)	55dB			
Sensor Break Detection	Sensor open for Thermocouple, RTD and mV inputs, Sensor short for RTD input, Below 1mA for 4-20mA input, Below 0.25VDC for 1 - 5VDC input, Not available for other inputs.			
Sensor Break Response Time	Within 4 seconds for Thermocouple, RTD and mV inputs, 0.1 second for 4-20mA and 1 - 5VDC inputs.			
<b>Digital Input (DI1 or DI2)</b>				
Number of Event Input	1			
Logic Low	-10VDC minimum, 0.8VDC maximum.			
Logic High	2VDC minimum, 10VDC maximum			
Functions	See the availability table			
<b>Analog Retransmission Output 1 /Output 2 /Output 3</b>				
Number of Outputs	3			
Output Signal	4-20mA, 0-20 mA, 0 - 10VDC			

<b>Specification</b>	<b>RSC</b>
Resolution	15 Bits
Accuracy	±0.05% of Span ± 0.0025% / °C
Load Resistance	0 to 500Ω for current output, 10KΩ minimum for Voltage Output
Output Regulation	0.01% for full load change
Output Setting Time	0.1Second (stable to 99.9%)
Isolation Breakdown	1000VAC min
Integral Linearity Error	±0.005% of span
Temperature Effect	±0.0025% of span / °C
Saturation Low	0mA or 0VDC
Saturation High	22.2mA or 5.55V, 11.1V min
Linear Output Ranges	0 - 22.2mA (0 - 20mA/4 - 20mA), 0 - 5.55VDC (0 - 5VDC, 1 - 5VDC), 0 - 11.1VDC (0 - 10VDC)
<b>Data Communication</b>	
Interface	RS-485
Protocol	Modbus RTU (Slave Mode)
Address	1 to 247
Baud Rate	2.8KBPS to 115.2KBPS
Parity Bit	None, Even or Odd
Stop Bit	1 or 2 Bits
Data Length	7 or 8 Bits
Communication Buffer	160 Bytes
<b>User Interface</b>	
Keypad	4 Keys
Display Type	4 Digit LCD Display
No of Display	2
Upper Display Size	0.58" (15mm)
Lower Display Size	0.3" (7.8mm)
<b>Programming Port</b>	
Interface	Micro USB
PC Communication Function	Firmware upgrade
<b>Digital Filter</b>	
Function	First Order
Time Constant	0,0.2, 0.5, 1, 2, 5, 10, 20, 30, 60 Seconds, Programmable
<b>Environmental and Physical Specifications</b>	
Operating Temperature	-10°C to 50°C
Storage Temperature	-40°C to 60°C
Humidity	0 to 90 % RH (Non-Condensing)
Altitude	2000 Meters Maximum
Pollution	Degree II
Insulation Resistance	20MΩ Minimum (@500V DC)
Dielectric Strength	2000VAC, 50/60 Hz for 1 Minute
Vibration Resistance	10 to 55 Hz, 10m/s <sup>2</sup> for 2 Hours
Shock Resistance	200 m/s <sup>2</sup> (20g)
Dimensions (W*H*D) (mm)	22.5*96*83
Weight (grams)	160
<b>Approval Standards</b>	
Safety	UL61010-1, CSA 22.2 No.61010-1-12, EN61010-1 (IEC1010-1)
Protective Class	IP66 for Panel (In process), IP20 for terminals and housing. All indoor use.
EMC	EN61326

## 1.4 Ordering Code

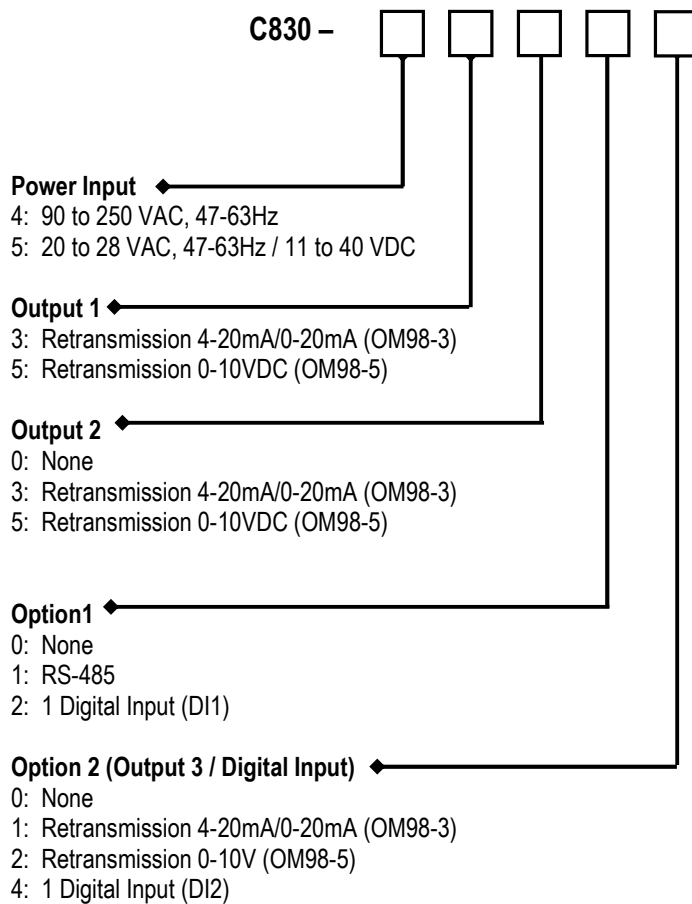

### 1.4.1 Accessories

OM98-3 = Isolated 4-20mA/0-20mA Retransmission Module  
OM98-5 = Isolated 0-10VDC Retransmission Module  
CPA98-1 = USB Programming Adaptor  
CCC98-1 = Programming Port Cable (1.5m)

### 1.4.2 Related Products





SNA10A = Smart Network Adaptor for third-party software, which converts up to 255 channels of RS-485 or RS-422 to be usable on an RS-232 Network.  
BC-Set = Configuration Software

## 1.5 Programming Port

A Micro USB Port provided on the device can be used to connect to a PC by using a programming port cable (CCC98-1) and a programming adapter (CPA98-1) for firmware upgrades. The device can also be connected to an ATE system for automatic calibration and testing using the micro-USB port. The programming port is used for off-line automatic setup and testing procedures only. Do not attempt to make any connections to this port while the device is being used during normal operation.

## 1.6 Display Board Keys

There are 4 Keys available in the display board for the user to operate as explained below.

1. **SCROLL KEY or ENTER KEY:**  This key is used to select a parameter to be viewed or adjusted.
2. **UP KEY:**  This key is used to increase the value of the selected parameter.
3. **DOWN KEY:**  This key is used to decrease the value of the selected parameter.
4. **RESET KEY:**  This key is used to revert the display to the home screen.

During power-up, the upper display will show PROG and the lower display will show the Firmware version for 6 seconds.

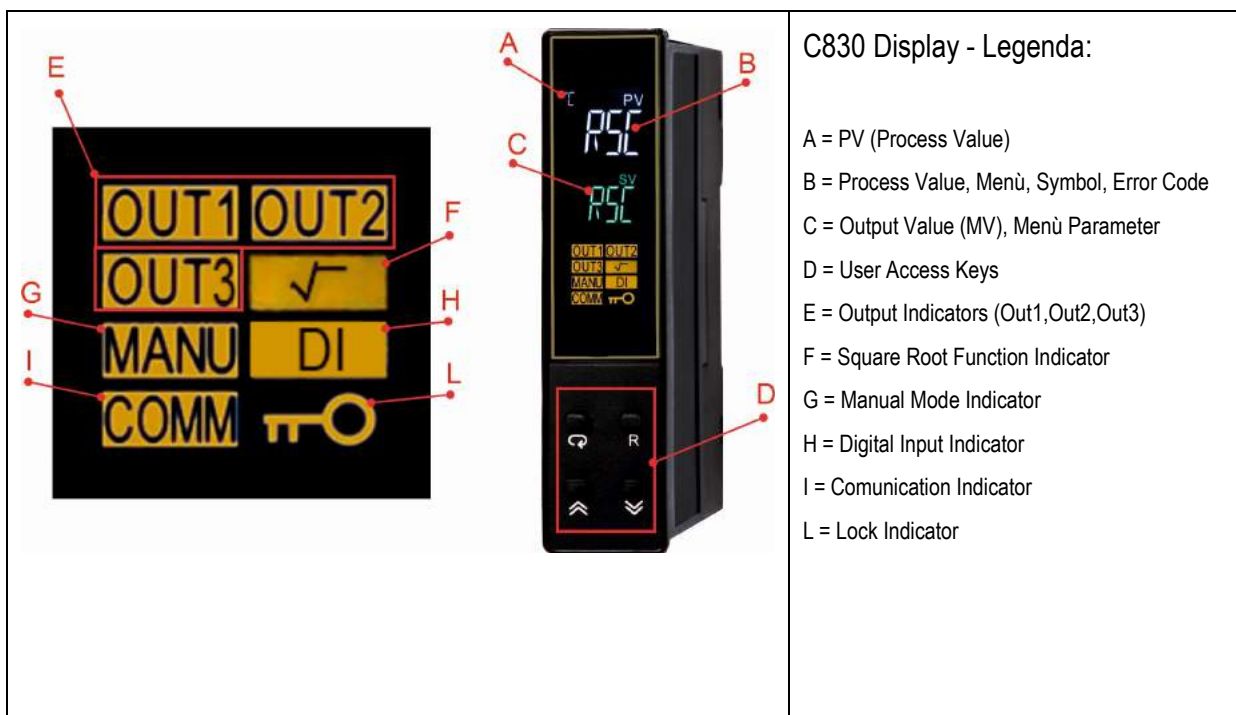

### 1-2.C830 Front Panel

A	À	B	À	C	Ç	D	Ð	E	Ë	F	Ë	G	Ë
H	Ë	I	Ë	J	Ë	K	Ë	L	Ë	M	Ë	N	Ë
O	Ë	P	Ë	Q	Ë	R	Ë	S	Ë	T	Ë	U	Ë
V	Ë	W	Ë	X	Ë	Y	Ë	Z	Ë				



1-3.How Character are Displayed on the LCD screen

## 1.7 Menu Flowchart

The Menu has been divided into 5 groups. They are as follows:



1. Basic Menu (bASE)
2. Output Menu(oUt)
3. Communication Menu(CoMM)
4. Manual Mode Menu (MANU)
5. Calibration Menu (CALI)

### 1.7.1 Basic Menu (bASE)

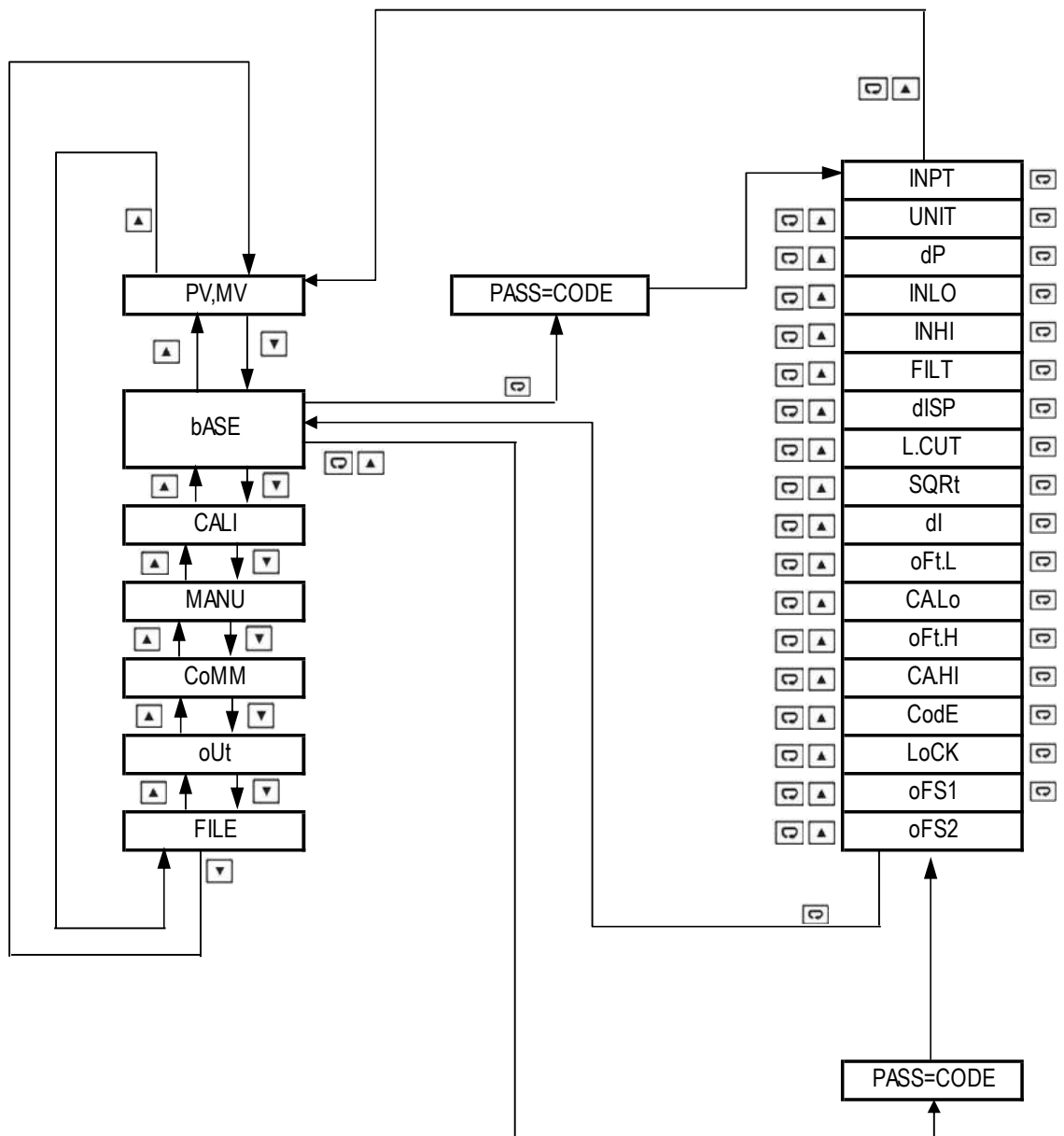
Use  or  key to get bASE in the lower display then use  key to enter to Base menu parameters.



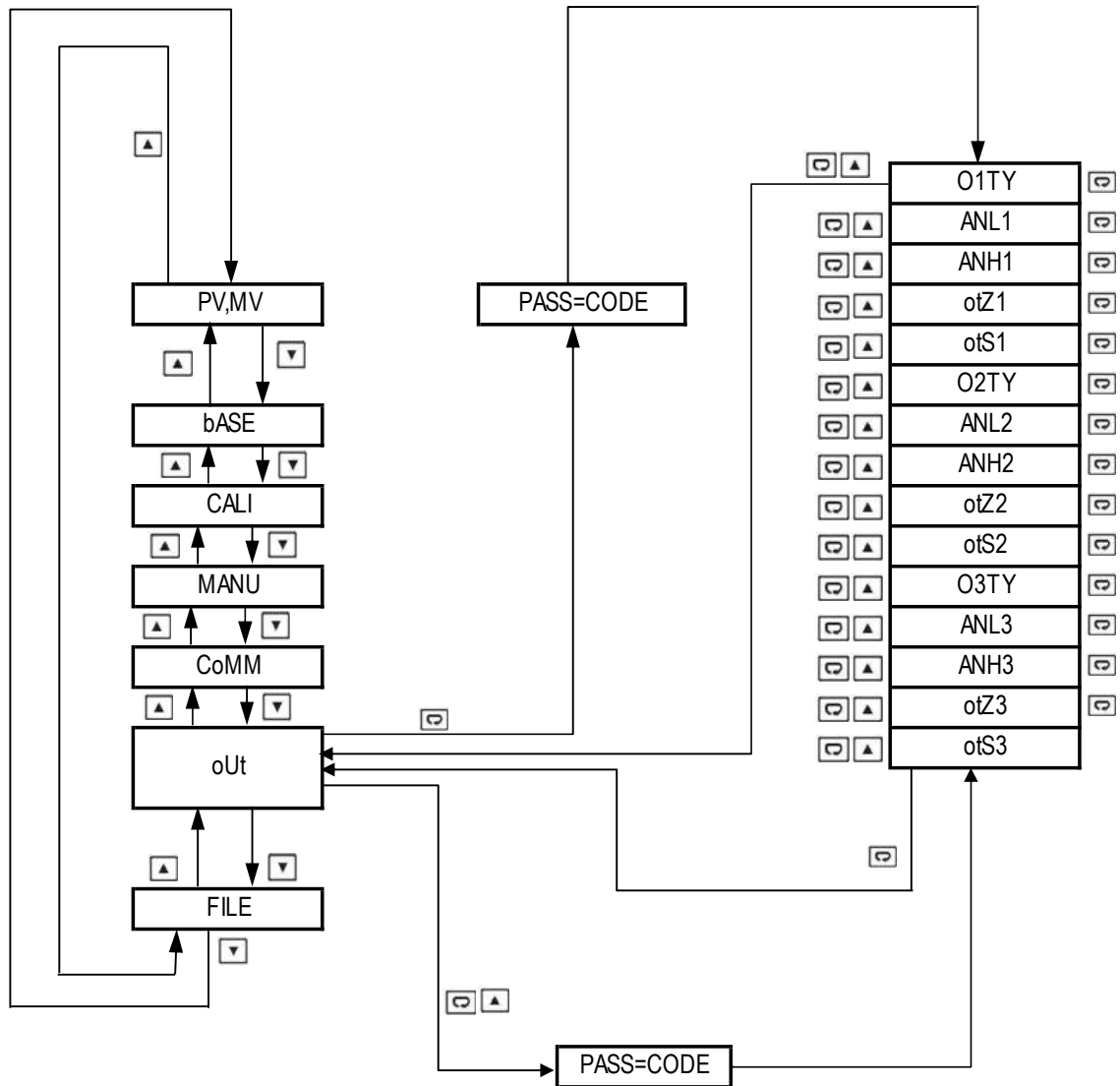

## 1.7.2 Output Menu (oUt)

Use  or  key to get oUT in the lower display then use  key to enter to output menu parameters.





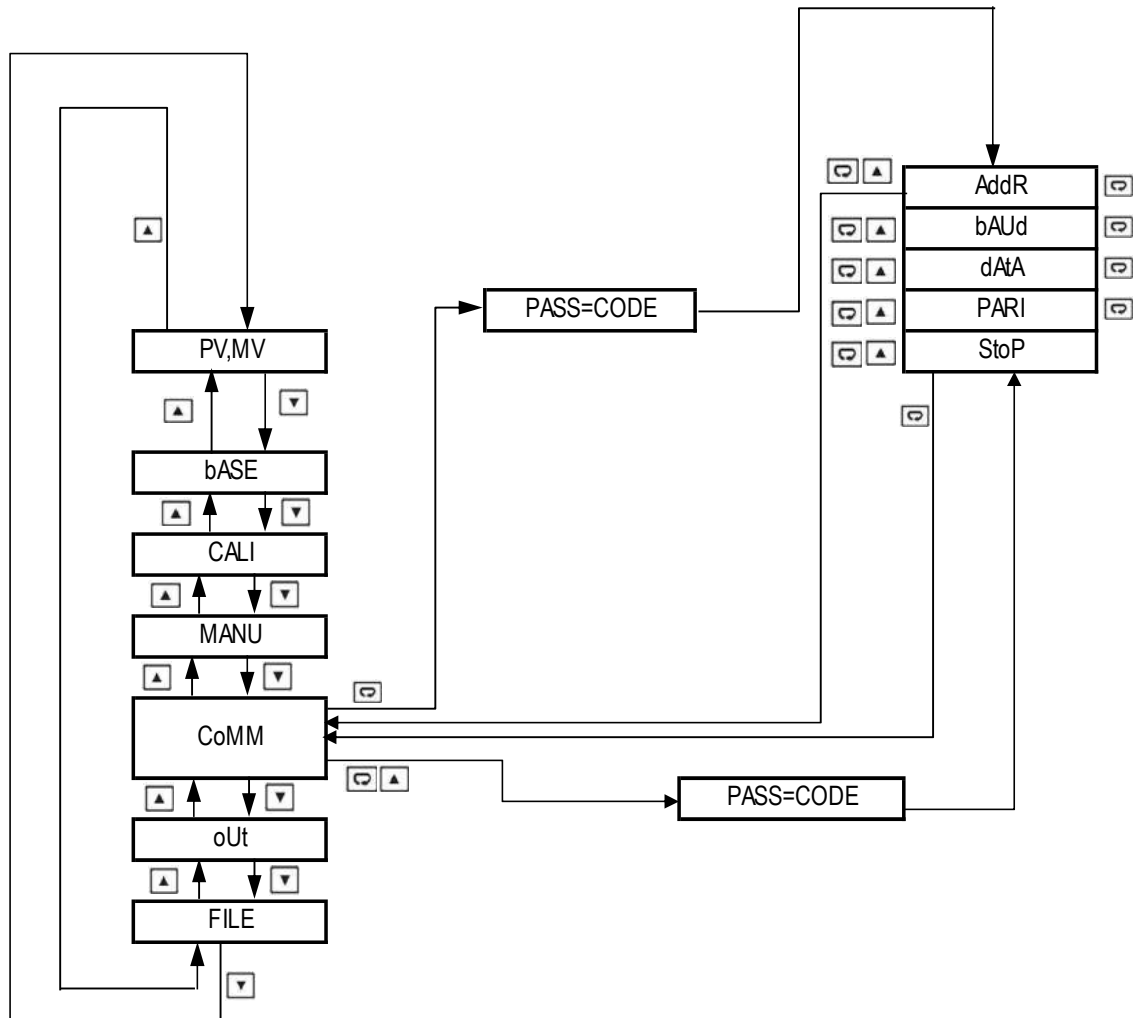

### 1.7.3 Communication Menu (CoMM)

Use  or  key to get CoMM in the lower display then use  key to enter into communication menu parameters.



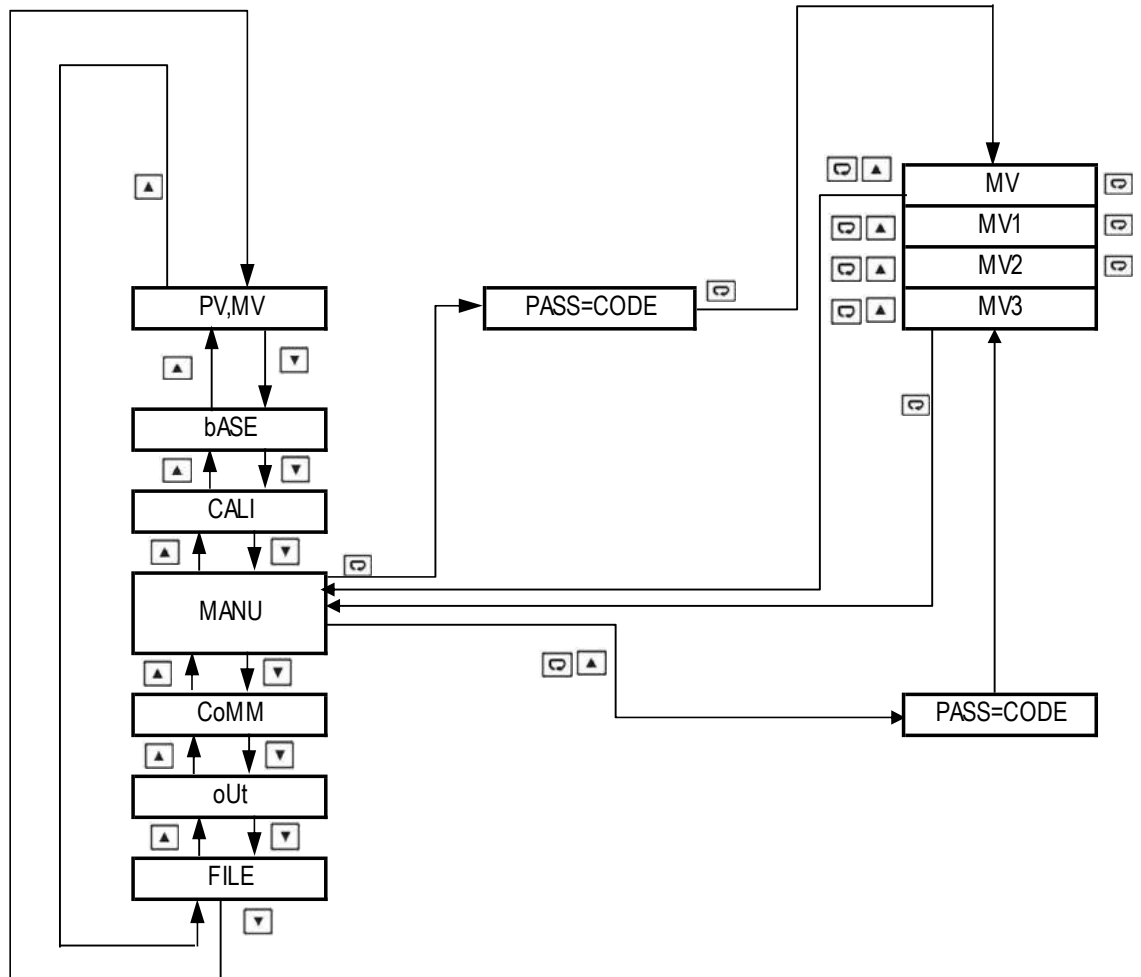

### 1.7.4 Manual Mode Menu

Use  or  key to get MANU in the lower display then use  key to enter into Manual Mode parameters.



### 1.7.5 Calibration Mode

Use  or  key to get CALI in the lower display then use  key to enter into Calibration Mode parameters.

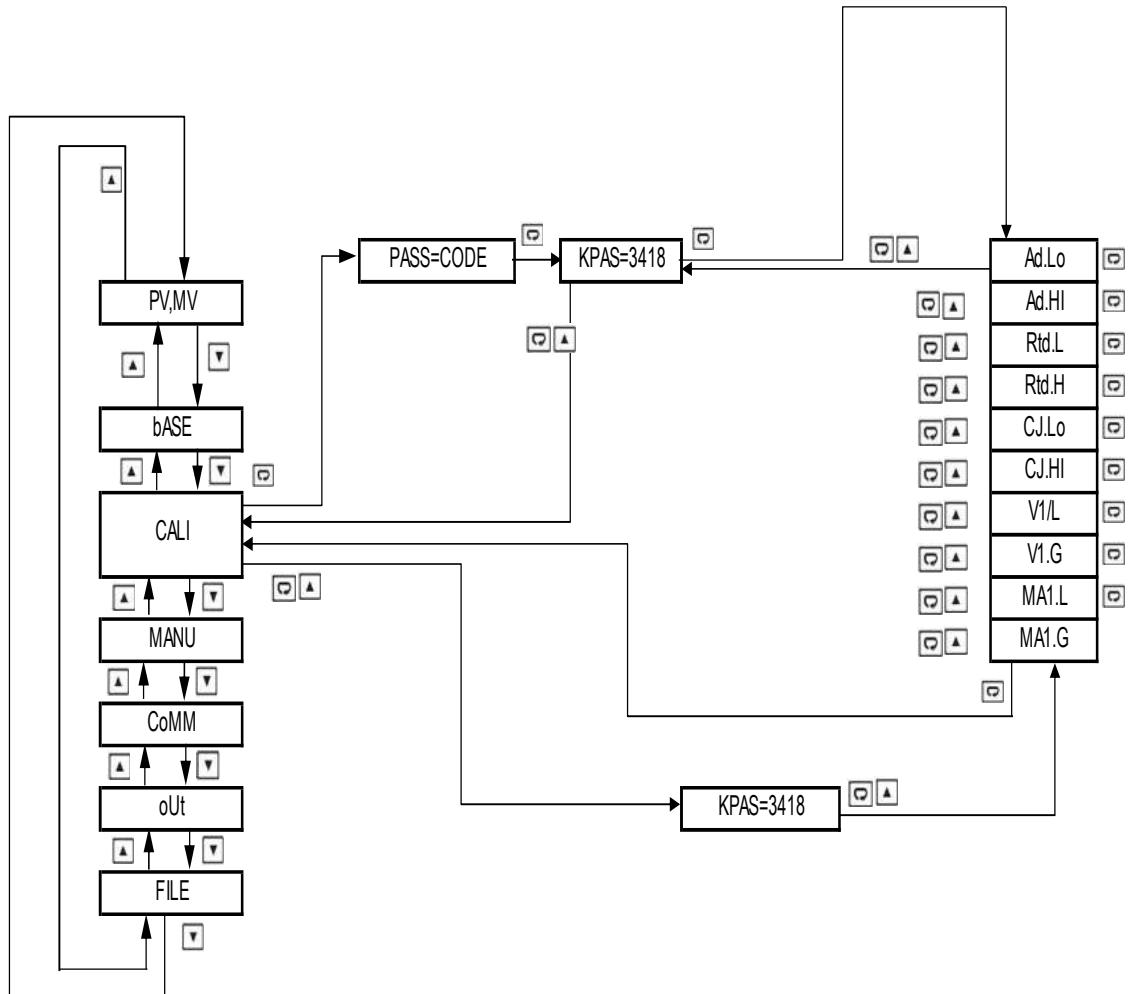

**Note:**

- The flow chart shows a complete list of all parameters. For actual application, the number of available parameters will vary depending on the setup and will be less than that shown in the flow chart.

### 1.8 Parameter Availability Table

Register Address	Parameter Notation	Existence Conditions
0	PASS	Exists unconditionally
1	INPT	Exists unconditionally
2	UNIT	Exists unconditionally
3	DP	Exists unconditionally
4	IN.Lo	Exists if INPT selects 4-20,0-20,0-50,0-60,0-5V,1-5V, or 0-10
5	IN.HI	

Register Address	Parameter Notation	Existence Conditions
6	FILT	Exists unconditionally
7	DISP	Exists unconditionally
8	LCUT	Exists unconditionally
9	SQRT	Exists if INPT selects 4-20,0-20,0-50,0-60,0-5V,1-5V, or 0-10
10	DI	Exists if OFS1 selects DI1 or OFS2 selects DI2
11	OFSTL	Exists unconditionally
12	CALO	Exists unconditionally
13	OFSTH	Exists unconditionally
14	CAHI	Exists unconditionally
15	CODE	Exists unconditionally
16	LOCK	Exists unconditionally
17	O1TY	Exists unconditionally
18	ANL1	Exists unconditionally
19	ANH1	Exists unconditionally
20	OTZ1	Exists unconditionally
21	OTS1	Exists unconditionally
22	O2TY	Exists unconditionally
23	ANL2	Exists unconditionally
24	ANH2	Exists unconditionally
25	OTZ2	Exists unconditionally
26	OTS2	Exists unconditionally
27	O3TY	Exists if OFS2 selects RETR
28	ANL3	
29	ANH3	
30	OTZ3	
31	OTS3	Exists if OFS1 selects RS-485
32	ADDR	
33	BAUD	
34	DATA	
35	PARI	
36	STOP	Exists if KPAS is correct
37	KPAS	
38	ADLO	
39	ADHI	
40	RTDL	
41	RTDH	
42	CJLO	
43	CJHI	
44	V1L	
45	V1G	
46	MA1L	
47	MA1G	
48	CJCT	Exists unconditionally

Register Address	Parameter Notation	Existence Conditions
49	CJCL	Exists unconditionally
50	PV	Exists unconditionally
51	MV	Exists unconditionally
52	MV1	Exists if MV selects ON
53	MV2	
54	MV3	
55	EROR	Exists unconditionally
56	MODE	Exists unconditionally
57	PROG	Exists unconditionally
58	CMND	Exists unconditionally
59	JOB	Exists unconditionally
60	OFS1	Exists unconditionally
61	OFS2	Exists unconditionally

### 1.9 Parameters Description

Modbus Register Address	Parameter Notation	Parameter Description	Range	Default Value	Data Type	Scale Low	Scale High
0	PASS	Security Password	Low: 0 High: 9999	0	R/W	0	65535
1	INPT	Input sensor selection	<b>0 J_tC</b> : J type Thermocouple <b>1 K_tC</b> : K type Thermocouple <b>2 T_tC</b> : T type Thermocouple <b>3 E_tC</b> : E type Thermocouple <b>4 B_tC</b> : B type Thermocouple <b>5 R_tC</b> : R type Thermocouple <b>6 S_tC</b> : S type Thermocouple <b>7 N_tC</b> : N type Thermocouple <b>8 L_tC</b> : L type Thermocouple <b>9 U_tC</b> : U type Thermocouple <b>10 P_tC</b> : P type Thermocouple <b>11 C_tC</b> : C type Thermocouple <b>12 D_tC</b> : D type Thermocouple <b>13 Pt.dN</b> : PT100 $\Omega$ DIN curve <b>14 Pt.JS</b> : PT 100 $\Omega$ JIS curve <b>15 4-20</b> : 4 - 20 mA linear current input <b>16 0-20</b> : 0 - 20 mA linear current input <b>17 0-50</b> : 0 - 50mV linear voltage input <b>18 0-60</b> : 0 - 60mV linear voltage input <b>19 0-5V</b> : 0 - 5V linear voltage input <b>20 1-5V</b> : 1 - 5V linear voltage input <b>21 0-10</b> : 0 - 10V linear voltage input	15	R/W	0	65535

Modbus Register Address	Parameter Notation	Parameter Description	Range	Default Value	Data Type	Scale Low	Scale High
2	UNIT	Input unit selection	<b>0</b> <i>oC</i> : °C unit <b>1</b> <i>oF</i> : °F unit <b>2</b> <i>Pu</i> : Process unit	0	R/W	0	65535
3	DP	Decimal point selection	<b>0</b> <i>No.dP</i> : No decimal point <b>1</b> <i>1-dP</i> : 1 decimal digit <b>2</b> <i>2-dP</i> : 2 decimal digits <b>3</b> <i>3-dP</i> : 3 decimal digits	1	R/W	0	65535
4	IN.Lo	Input low scale value	Low: -19999 High: 45536 IN.Lo ≠ IN.HI	-17.8°C (0.0°F)	R/W	-19999	45536
5	IN.HI	Input high scale value	Low: -19999 High: 45536 IN.Lo ≠ IN.HI	37.8°C (100.0°F)	R/W	-19999	45536
6	FILT	Filter damping time constant of PV	<b>0</b> <b>0</b> : 0 second time constant <b>1</b> <b>0.2</b> : 0.2 second time constant <b>2</b> <b>0.5</b> : 0.5 second time constant <b>3</b> <b>1</b> : 1 second time constant <b>4</b> <b>2</b> : 2 second time constant <b>5</b> <b>5</b> : 5 second time constant <b>6</b> <b>10</b> : 10 second time constant <b>7</b> <b>20</b> : 20 second time constant <b>8</b> <b>30</b> : 30 second time constant <b>9</b> <b>60</b> : 60 second time constant	2	R/W	0	65535
7	DISP	MV display selection	<b>0</b> <i>MV1</i> : Display MV1 <b>1</b> <i>MV12</i> : Display MV1 & MV2 <b>2</b> <i>CYCL</i> : Display all MV cycled	0	R/W	0	65535
8	LCUT	Input low cut value	<b>-1</b> <i>OFF</i> or Low: 0 High: 20000 for °C Low: 0 High: 36000 for °F	OFF	R/W	-19999	45536

Modbus Register Address	Parameter Notation	Parameter Description	Range	Default Value	Data Type	Scale Low	Scale High
9	SQRT	Square root function	<b>0 OFF:</b> Square root disable <b>1 oUt1:</b> Square root enable for output 1 <b>2 ot.12:</b> Square root enable for output 1 and output 2 <b>3 ALL:</b> Square root enable for all outputs	0	R/W	0	65535
10	DI	Digital input function	<b>0 NoNE:</b> None <b>1 MA.Ho:</b> Hold max value of PV <b>2 DA.Ho:</b> Hold current value of PV <b>3 ZErO:</b> Force PV to 0	0	R/W	0	65535
11	OFTL	Offset value for low point calibration	Low: -1999 High: 1999	0	R/W	-19999	45536
12	CALO	Input signal value during low point calibration	Low: -19999 High: 45536 CALO ≠CAHI.	0	R/W	-19999	45536
13	OFTH	Offset value for high point calibration	Low: -1999 High: 1999	0	R/W	-19999	45536
14	CAHI	Input signal value during high point calibration	Low: -19999 High: 45536 CAHI ≠CALO.	1000	R/W	-19999	45536
15	CODE	Security code for parameter protection	Low: 0 High: 9999	0	R/W	0	65535
16	LOCK	Parameters lock	<b>0 OFF:</b> Lock off <b>1 oN:</b> Lock on	0	R/W	0	65535
17	O1TY	Output 1 signal type	<b>0 0-20:</b> 0-20 mA linear current <b>1 4-20:</b> 4-20 mA linear current <b>2 0-10:</b> 0-10V linear voltage <b>3 0-5V:</b> 0-5V linear voltage <b>4 1-5V:</b> 1-5V linear voltage <b>5 2-10:</b> 2-10V linear voltage	1	R/W	0	65535
18	ANL1	Output 1 retransmission low value	Low: -19999 High: 45536	-17.8°C (0.0 °F)	R/W	-19999	45536
19	ANH1	Output 1 retransmission high value	Low: ANL1+1 High: 45536	37.8°C (100.0°F)	R/W	-19999	45536

Modbus Register Address	Parameter Notation	Parameter Description	Range	Default Value	Data Type	Scale Low	Scale High
20	OTZ1	Output 1 zero adjustment	Low: -1.000 High 1.000	0	R/W	-19999	45536
21	OTS1	Output 1 span adjustment	Low: -1.000 High 1.000	0	R/W	-19999	45536
22	O2TY	Output 2 signal type	<b>0 0-20:</b> 0-20 mA linear current <b>1 4-20:</b> 4-20 mA linear current <b>2 0-10:</b> 0-10V linear voltage <b>3 0-5V:</b> 0-5V linear voltage <b>4 1-5V:</b> 1-5V linear voltage <b>5 2-10:</b> 2-10V linear voltage	1	R/W	0	65535
23	ANL2	Output 2 retransmission low value	Low: -19999 High: 45536	-17.8°C (0.0 °F)	R/W	-19999	45536
24	ANH2	Output 2 retransmission high value	Low: ANL2+1 High: 45536	37.8°C (100.0°F)	R/W	-19999	45536
25	OTZ2	Output 2 zero adjustment	Low: -1.000 High 1.000	0	R/W	-19999	45536
26	OTS2	Output 2 span adjustment	Low: -1.000 High 1.000	0	R/W	-19999	45536
27	O3TY	Output 3 signal type	<b>0 0-20:</b> 0-20 mA linear current <b>1 4-20:</b> 4-20 mA linear current <b>2 0-10:</b> 0-10V linear voltage <b>3 0-5V:</b> 0-5V linear voltage <b>4 1-5V:</b> 1-5V linear voltage <b>5 2-10:</b> 2-10V linear voltage	1	R/W	0	65535
28	ANL3	Output 3 low point retransmission value	Low: -19999 High: 45536	-17.8°C (0.0 °F)	R/W	-19999	45536
29	ANH3	Output 3 high point temperature	Low: ANL3+1 High: 45536	37.8 °C (100.0 °F)	R/W	-19999	45536
30	OTZ3	Output 3 zero adjustment	Low: -1.000 High 1.000	0	R/W	-19999	45536
31	OTS3	Output 3 span adjustment	Low: -1.000 High 1.000	0	R/W	-19999	45536





Modbus Register Address	Parameter Notation	Parameter Description	Range	Default Value	Data Type	Scale Low	Scale High
32	ADDR	Address assignment of digital communication	Low: 1 High: 255	1	R/W	0	65535
33	BAUD	Baud rate of digital communication	<b>0 2K4:</b> 2.4 Kbits/s baud rate <b>1 4K8:</b> 4.8 Kbits/s baud rate <b>2 9K6:</b> 9.6 Kbits/s baud rate <b>3 14K4:</b> 14.4 Kbits/s baud rate <b>4 19K2:</b> 19.2 Kbits/s baud rate <b>5 28K8:</b> 28.8 Kbits/s baud rate <b>6 38K4:</b> 38.4 Kbits/s baud rate <b>7 57K6:</b> 57.6 Kbits/s baud rate <b>8 115K:</b> 115.2 Kbits/s baud rate	6	R/W	0	65535
34	DATA	Data bit count of digital communication	<b>0 7bit:</b> 7 data bits <b>1 8bit:</b> 8 data bits	1	R/W	0	65535
35	PARI	Parity bit of digital communication	<b>0 EVEN:</b> Even Parity <b>1 Odd:</b> Odd parity <b>2 NoNE:</b> No parity bit	2	R/W	0	65535
36	STOP	Stop bit count of digital communication	<b>0 1bit:</b> One stop bit <b>1 2bit:</b> Two stop bits	1	R/W	0	65535
37	KPAS	Calibration password	Low: 0 High: 9999	0	R/W	0	65535
38	ADLO	mV calibration low coefficient	Low: -1999 High: 1999	-----	R/W	-19999	45536
39	ADHI	mV calibration high coefficient	Low: -1999 High: 1999	-----	R/W	-19999	45536
40	RTDL	RTD calibration low coefficient	Low: -1999 High: 1999	-----	R/W	-19999	45536
41	RTDH	RTD calibration high coefficient	Low: -1999 High: 1999	-----	R/W	-19999	45536
42	CJLO	Cold junction calibration low coefficient	Low: -5.00 High: 40.00	-----	R/W	-19999	45536
43	CJHI	Cold junction calibration high coefficient	Low: -1999 High: 1999	-----	R/W	-19999	45536
44	V1L	V1 calibration low coefficient	Low: -1999 High: 1999	-----	R/W	-19999	45536
45	V1G	V1 calibration high coefficient	Low: -1999 High: 1999	-----	R/W	-19999	45536
46	MA1L	MA1 calibration low coefficient	Low: -1999 High: 1999	-----	R/W	-19999	45536

Modbus Register Address	Parameter Notation	Parameter Description	Range	Default Value	Data Type	Scale Low	Scale High
47	MA1G	MA1 calibration high coefficient	Low: -1999 High: 1999	-----	R/W	-19999	45536
48	CJCT	Cold Junction Temperature	Low: -4000 High: 9000	-----	R	-19999	45536
49	CJCL	Sense voltage during cold junction calibration low	Low: 0 High: 7552	-----	R	0	65535
50	PV	Process value	Low: -19999 High: 45536	-----	R	-19999	45536
51	MV	Manual control function	<b>0 oFF:</b> Manual control off <b>1 oN:</b> Manual control on	0	R/W	0	65535
52	MV1	Output 1 percentage value	Low: 0.00 High: 100.00	-----	R (R/W, manual)	0	65535
53	MV2	Output 2 percentage value	Low: 0.00 High: 100.00	-----	R (R/W, manual)	0	65535
54	MV3	Output 3 percentage value	Low: 0.00 High: 100.00	-----	R (R/W, manual)	0	65535
55	EROR	Error code	Low: 0 High: 65535	-----	R	0	65535
56	MODE	Operation mode	Low: 0 High: 65535	-----	R	0	65535
57	PROG	Program code	R24: 24. XX	-----	R	0	65535
58	CMND	Command code	Low: 0 High: 65535	-----	R/W	0	65535
59	JOB	Job code	Low: 0 High: 65535	-----	R/W	0	65535
60	OFS1	Option function 1 selection	<b>0 NoNE:</b> No selected <b>1 R485:</b> RS-485 <b>2 dI1:</b> Digital input 1	2	R/W	0	65535
61	OFS2	Option function 2 selection	<b>0 NoNE:</b> No selected <b>1 REtR:</b> Retransmission output <b>2 dI2:</b> Digital input 2	0	R/W	0	65535

## 2 Installation and Wiring

 Sometimes dangerous voltages capable of causing death are present in this instrument. Before doing the installation or any troubleshooting procedures, the power to the equipment must be switched off and isolated. Units suspected of being faulty must be disconnected and removed to a properly equipped workshop for testing and repair. Component replacement and internal adjustments must be made by a qualified maintenance person only.

 To minimize the possibility of fire or shock hazards, do not expose this instrument to rain or excessive moisture.

 Do not use this instrument in areas under hazardous conditions such as excessive shock, vibration, dirt, moisture, corrosive gases or oil. The ambient temperature of the area should not exceed the maximum rating specified in the specification

 Remove stains from this equipment using a soft, dry cloth. Do not use harsh chemicals, volatile solvents such as thinner or strong detergents to clean the equipment in order to avoid deformation.

### 2.1 Unpacking

Upon receipt of the shipment, remove the signal conditioner from the carton and inspect the unit for shipping damage. If any damage is found, contact your local representative immediately. Note the model number and serial number for future reference when corresponding with our service centre. The serial number (S/N) is labelled on the box and the housing of the controller.

The signal conditioner is designed for indoor use only and is not intended for use in any hazardous area. It should be kept away from shock, vibration, and electromagnetic fields (such as variable frequency drives), motors and transformers. It is intended to operate under the following environmental conditions.

Environmental Parameter	Specification
Operating Temperature	-10°C to 50 °C
Humidity	0% to 90% RH(Non-condensing)
Altitude	2000 M Maximum

#### **2-1. Environmental Specification**

## 2.2 Dimension

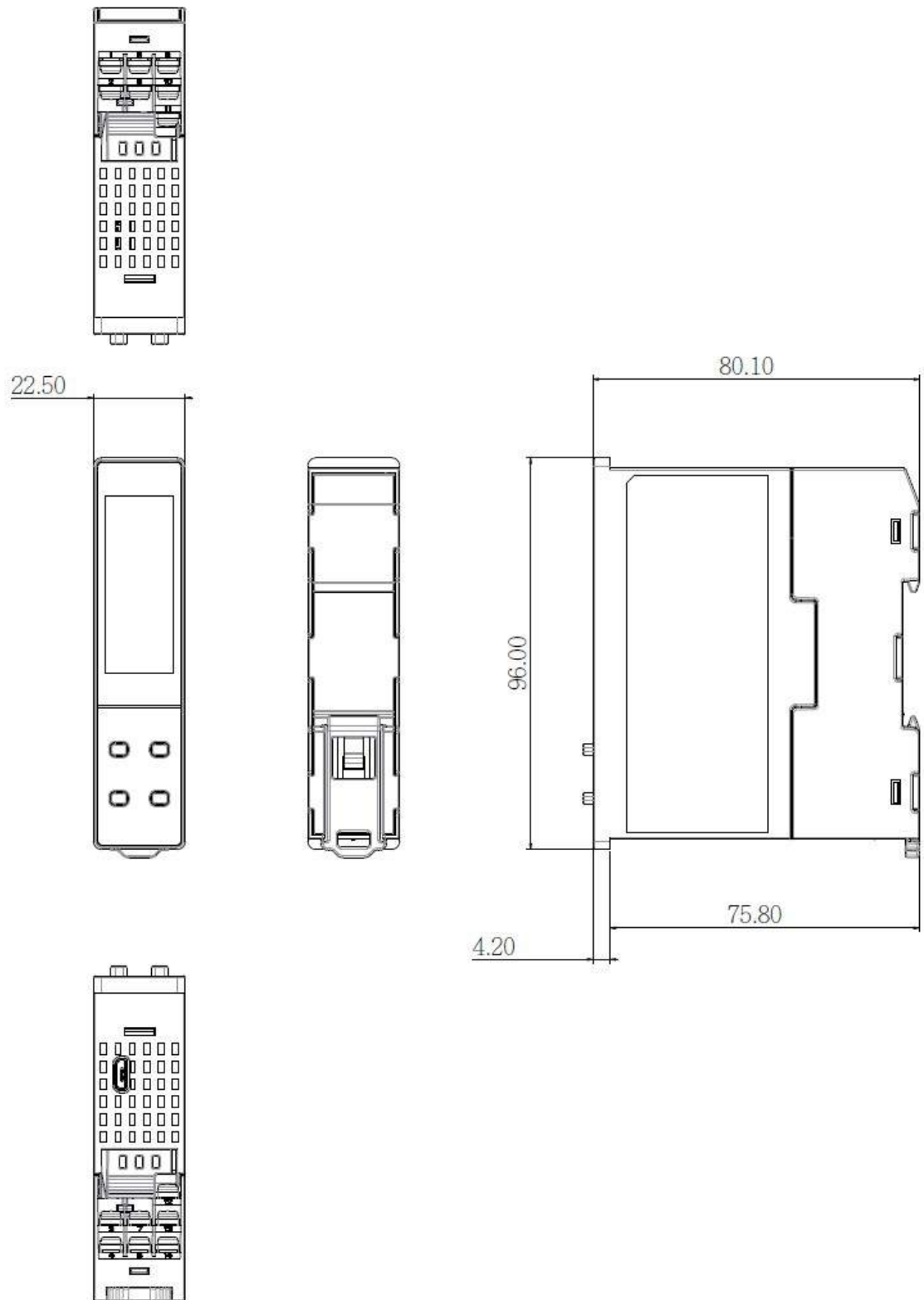

## 2-1 Dimension

## 2.3 Wiring

 Sometimes dangerous voltages capable of causing death are present in this instrument. Before doing the installation or any troubleshooting procedures, the power to the equipment must be switched off and isolated. Units suspected of being faulty must be disconnected and removed to a properly equipped workshop for testing and repair. Component replacement and internal adjustments must be made by a qualified maintenance person only. The utmost care must be taken to ensure that the maximum voltage rating specified on the label is not exceeded.

It is recommended that the supply power of these units be protected by fuses or circuit breakers rated at the lowest value possible. All units should be installed inside a suitably grounded metal enclosure to prevent live parts being accessible to human hands and metal tools. All wiring must conform to appropriate standards of good practice and local codes and regulations. Wiring must be suitable for the voltage, current, and temperature rating of the system. The tightening torque on the Screw terminals should not exceed 1 N-m (8.9 Lb-in or 10.2 Kg F-cm). Except Thermocouple Wiring, all other wires used are to be standard copper conductors with the maximum Gauge not exceeding 18AWG. Before powering on the device, the equipment ground must be connected with a minimum of 1.6mm diameter conductor for protective grounding.

### 2.3.1 Terminal Connection

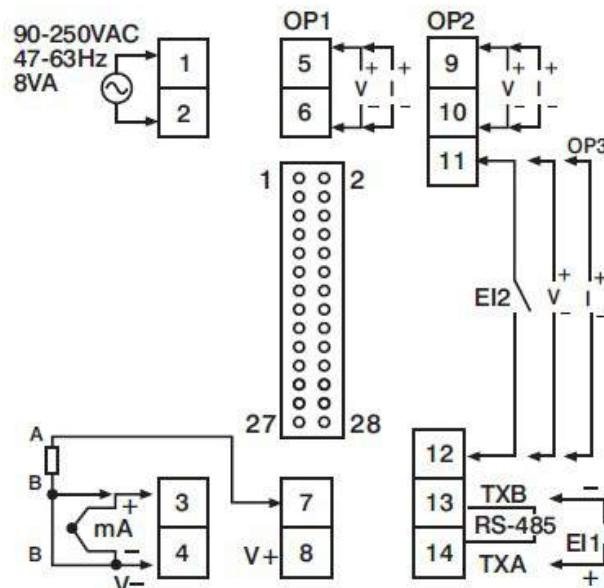

**2-2 Terminal Connection**

### 2.3.2 Power Wiring

The device is designed to operate at either 11-26VAC/VDC or 90-250VAC depending on power input option ordered. Check that the installation voltage corresponds with the power rating indicated on the product label before connecting power to the controller. Near the controller, a fuse and a switch rated at 2A/250VAC should be equipped as shown below.

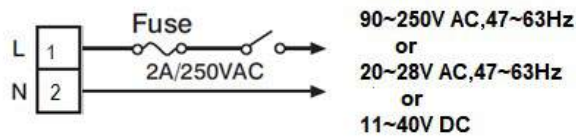

### 2-3. Power Wiring

**⚠** This equipment is designed for installation in an enclosure which provides adequate protection against electric shock. The enclosure must be connected to earth ground.

**⚠** Local requirements regarding electrical installation should be rigidly observed. Consideration should be given to prevent unauthorized persons from accessing the power terminals.

#### 2.3.3 Sensor Installation

Proper sensor installation can eliminate many problems in a control system. The probe should be placed so that it can detect any temperature change with minimal thermal lag. In a process that requires fairly constant heat output, the probe should be placed close to the heater. In a process where the heat demand is variable, the probe should be placed close to the work area. Some experiments with probe location are often required to find this optimum position.

In a liquid process, the addition of a stirrer or agitator can help to eliminate thermal lag. Since the thermocouple is basically a point measuring device, placing more than one thermocouple in parallel can provide average temperature readout and produce better results in most air heated processes.

The proper sensor type is also a very important factor to obtain precise measurements. The sensor must have the correct temperature range to meet the process requirements. In special processes, the sensor might need to have different requirements such as being leak-proof, ant vibration, antiseptic, etc. Standard sensor limits of error are  $\pm 4^{\circ}\text{F}$  ( $\pm 2^{\circ}\text{C}$ ) or 0.75% of sensed temperature (half that for special) plus drift caused by improper protection or an over-temperature occurrence. This error is far greater than controller error and cannot be corrected on the sensor except by proper selection and replacement.

#### 2.3.4 Input Wiring

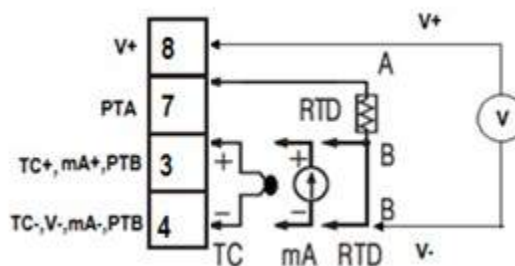

### 2-4 Input Wiring

## 2.3.5 Retransmission Output Wiring

### 2.3.5.1 Output 1

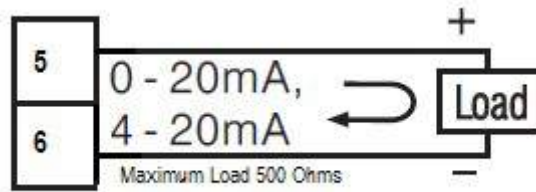

#### 2-5 Output 1 Linear Current

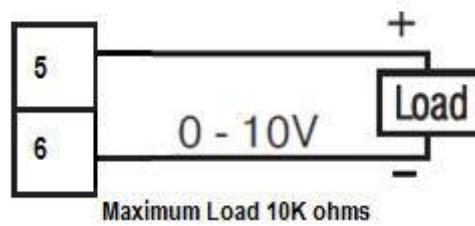

#### 2-6 Output 1 Linear Voltage

### 2.3.5.2 Output 2

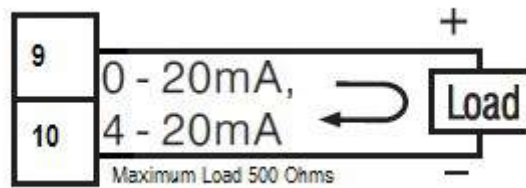

#### 2-7 Output 2 Linear Current

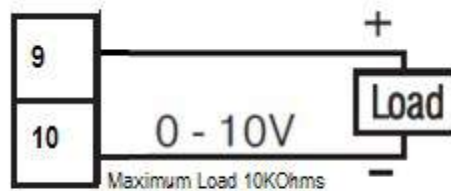

#### 2-8 Output 2 Linear Voltage

### 2.3.5.3 Output 3

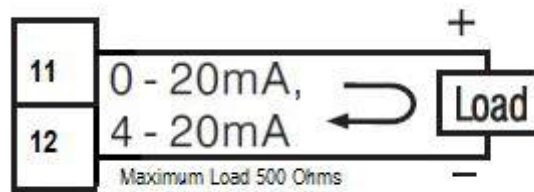

**2-9 Output 3 Linear Current**

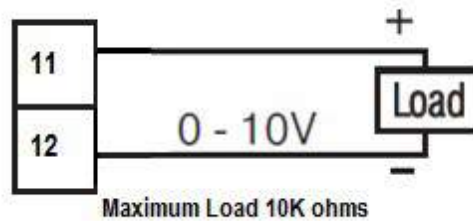

**2-10 Output 3 Linear Voltage**

### 2.3.6 Digital Input Wiring

The digital input can accept a switch (dry contact) or an open collector signal. The digital input function is activated as the switch is closed or an open collector (or a logic signal) is pulled down. Only one Event input can be used.

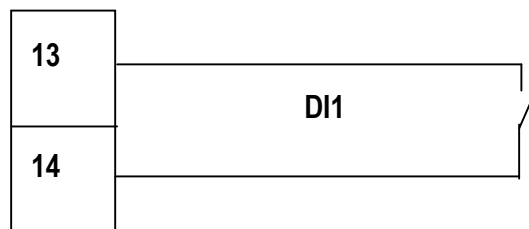
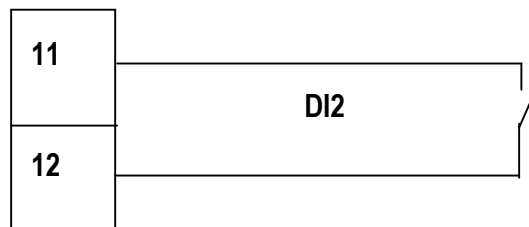

**2-11 Digital Input Wiring**





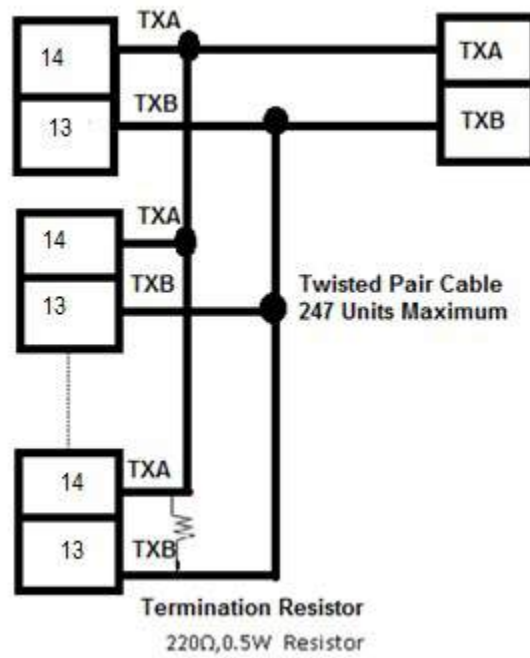

### 2.3.7 RS-485 Data Communication



**2-12 RS-485 Wiring**

## 3 Programming

During Power on the device will show the PV on the upper display and MV on the lower display. Press  to enter the setup menu. Use   keys to select the desired parameter. Use  key to reset and go back to the home screen. In the set-up menu, the upper display indicates the parameter symbol, and the lower display indicates the value of the selected parameter.

### 3.1 User Security

There are two parameters PASS (password) and CODE (security code) which will control the data security function for accessing the setup parameters.

If the CODE=PASS then the user can access the setup parameters. If the CODE≠PASS then the user can't access the setup parameters.

There is one more parameter LOCK is available to control the parameter change. If the LOCK is on then the parameters can't be changed. If the LOCK is OFF then the parameters can be changed.

### 3.2 Calibration Password

The calibration of the device is protected with separate security access. The parameter KPAS value is 3418 then only the user can access the calibration parameters. Otherwise, the calibration parameter can't be accessed.

### 3.3 Signal Input

**INPT:** Select the sensor type or signal type for signal input

**Range:** (Thermocouple) J\_tC, K\_tC, T\_tC, E\_tC, B\_tC, R\_tC, S\_tC, N\_tC, L\_tC, U\_tC, P\_tC, C\_tC, d\_tC  
(RTD) PT.DN, PT.JS  
(Linear) 4-20, 0-20, 0-5V, 1-5V, 0-10

**UNIT:** Select the processing unit

**Range:** °C, °F, PU (Process unit). If the unit is neither °C or °F, then selects PU.

**DP:** Select the resolution of the process value.

**Range:** For Thermocouple and RTD Signal NO.DP, 1-DP and For Linear Signal NO. DP, 1- DP, 2-DP, 3-DP

**IN.Lo:** Select the low scale value for the linear type input.

**IN.Hi:** Select the high scale value for the linear type input.

**How to use INLO and INHI:**

If 4-20mA is selected for INPT, let SL represent the low scale of the input signal (i.e. 4 mA), let SH represent the high scale of the input signal (i.e. 20 mA). S represents the current input signal value; the conversion curve of the process value is shown as follows:

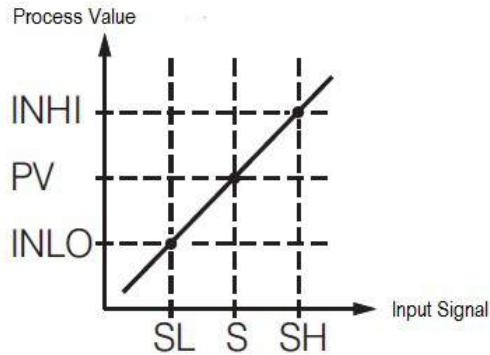

### 3-1. Conversion Curve for Linear Type Process Signal

Formula:  $PV = INLO + (INHI - INLO) \left( \frac{S - SL}{SH - SL} \right)$

Example: A 4-20mA current loop pressure transducer with a range of 0-15 kg/cm is connected to the input. The following parameters should be set as follows:

INPT = 4-20, INLO = 0.00, INHI = 15.00, DP = 2-DP

Of course, the user may select a different value for DP to alter the resolution.

### 3.4 Output Type

The Output type should be selected properly on the output type selection parameter O1TY, O2TY and O3TY Parameters. The option selection in oFS2 needs to select Retransmission to enable output3.

### 3.5 Retransmission

The signal conditioner will output (retransmit) PV on its output terminals of output1, output2 and output3. ANL1 and ANH1 are adjusted to specify the low scale and high scale values of output1 retransmission. Similarly, ANL2, ANL3, ANH2 and ANH3 parameters are adjusted for output2 and output3.

### 3.6 Zero and Span adjustment

The signal conditioner has the option to adjust the zero and span of the outputs to meet the required accuracy. The user can adjust the parameters otZ1, otZ2 and otZ3 to adjust the zero value of the output1, output2 and output3 respectively. The user can adjust the parameters otS1, otS2 and otS3 to adjust the span value of the output1, output2 and output3 respectively. The allowable range for zero and span adjustment is from -1.000 to 1.000.

### 3.7 Square Root function (SQRT)

The square root function (SQRT) function will output the square root value of the PV. The square root function will be enabled by setting the parameter SQRT. The Square root function will output based on the below formula.

$$PV = \text{SQRT} \left( \left( \frac{PV - IN.Lo}{IN.HI - IN.Lo} \right) \times (IN.HI - IN.Lo) + IN.Lo \right)$$

The SQRT function can't do for negative values of PV. If  $PV \leq IN.Lo$ , then the SQRT will consider IN.Lo as PV.

### 3.8 User Calibration

Each unit is calibrated in the factory before shipment. The user can still modify the calibration in the field.

The basic calibration of the device is highly stable and set for life. User calibration allows the user to offset the permanent factory calibration in order to:

- ❖ Calibrate the device to meet a user reference standard.
- ❖ Match the calibration of the device to that of a particular transducer or sensor input.
- ❖ Calibrate the device to suit the characteristics of a particular installation.
- ❖ Remove long term drift in the factory set calibration.

There are two parameters: Offset Low (OFTL) and Offset High (OFTH) for adjustment to correct an error in the process value.

There are two parameters for the sensor input. These two signal values are CALO and CAHI. The input signal low and high values are to be entered in the CALO and CAHI parameters respectively.

Refer to [section 1.6](#) for key operation and [section 1.7](#) for the operation flowchart. Use  $\uparrow$  and  $\downarrow$  keys to get the CALI page then  $\square$  key to access the calibration parameters. Then, press and release the  $\square$  key to navigate to the calibration low parameter OFTL. Send your low signal to the sensor input of the device, then press and release the  $\square$  key. If the process value (the upper display) is different from the input signal, the user can use  $\uparrow$  and  $\downarrow$  keys to change the OFTL value (the lower display) until the process value is equal to the value the user needs. Press and hold the  $\square$  key for 5 seconds to complete the low point calibration. A similar procedure is applied for high scale calibration.

As shown below, the two points OFTL and OFTH construct a straight line. For the purpose of accuracy, it is best to calibrate with the two points as far apart as possible. After the user calibration is complete, the input type will be stored in the memory. If the input type is changed, a calibration error will occur and an error code *CAEr* is displayed.

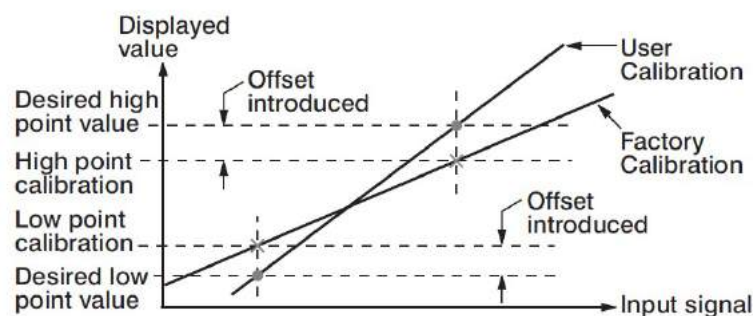

**3-2. Two Point User Calibration**

### 3.9 Digital Filter

In certain applications, the process value is too unstable to be read. To improve this, a programmable low pass filter incorporated in the controller can be used. This is a first order filter with a time constant specified by the FILT parameter. A value of 0.5 seconds is used as a factory default. Adjust FILT to change the time constant from 0 to 60 seconds. 0 seconds represents no filter applied to the input signal. The filter is characterized by the following diagram.

#### **Note**

The Filter is available only for the process value (PV) and is performed for the displayed value only.

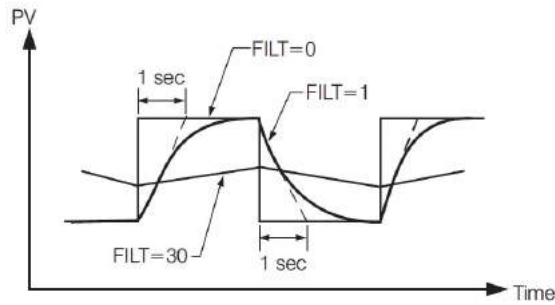

**3-3.Filter Characteristics**

### 3.10 Manual Control

Some application requires to test with the manual output from the signal conditioner. For this, the manual mode can be used. Use  $\blacktriangledown/\blacktriangle$  keys to access the MANU mode parameters. Use  $\square$  key to navigate to the manual mode control parameter MV. Set MV to ON to start the manual mode output. Use the  $\square$  key to select the desired output parameters MV1, MV2 and MV3. Use the  $\blacktriangledown/\blacktriangle$  keys to set the required output values. Set MV to OFF to stop the manual output.

### 3.11 Factory Default

The signal conditioner parameters can be loaded with default values listed in the [parameter description table](#). In certain situation it is desirable to retain these values after the values of the parameters have been changed. The below procedure to be followed to reload the default values.

1. Use  $\blacktriangledown/\blacktriangle$  keys to access the FILE parameters
2. Set PASS= CODE to access other parameters
3. Select the dFLt in File
4. Press and hold  $\square$  for 5 seconds or until the upper display FILE flash for a moment.

The default values of all parameters are loaded now.

### 3.12 Data Communication

The device support RS-485 Modbus RTU protocol for data communication. Using a PC for data communication is the most economical way. The signal is transmitted and received through the PC communication Port. Since a standard PC can't support an RS-485 port, a network adaptor such as an RS232 to RS485 Converter or USB to Serial Converter must be used to convert RS-485 to RS-232 or USB for a PC. Many RS-485 units (up to 247 units) can be connected to one RS-232 port or USB Port. Therefore, a PC with 4 comm. ports can communicate with up to 988 units. It is quite economical.

#### 3.12.1 RS-485 Setup

- ❖ Set oFS1 to RS485
- ❖ Set individual addresses for units connected to the same port.
- ❖ Set the Baud Rate (BAUD), Data Bit (DATA), Parity Bit (PARI) and Stop Bit (STOP) such that these values are accordant with PC setup conditions.

### 3.13 Digital Input

One digital Input is available in this signal conditioner. Refer [section 2.3.6](#) for wiring a digital input. The digital input accepts a digital (on/off) type signal. The digital input can be used via DI1 or DI2.

Types of signals that can be used to switch the digital input as below.

- ❖ Relay
- ❖ Switch contacts
- ❖ Open collector Pull Low
- ❖ TTL logic level

One of the below functions can be chosen by using DI in the setup menu. The digital input needs to be selected in oFS1 or oFS2 as dl1 or dl2. Only one digital input DI1 or DI2 can be used.

### 3.13.1 Digital Input Functions

1. NONE
2. MA.Ho
3. dA.Ho
4. ZERo

**NONE:** No digital input function. If chosen, the digital input function is disabled.

**MA.Ho:** If chosen, the maximum value of PV during the digital input period will be retransmitted. If the PV changes to lower value the output will not change to the lower value. If the PV is changed to a higher value the output value will change.

**dA.Ho:** If chosen the output will not change for the change in PV. It will keep retransmitting the PV at the rising edge of DI

**ZERo:** If chosen, the current PV will become zero for retransmitting.

## 4 Calibration

 Do not proceed through this section unless there is a definite need to re-calibrate the controller. All previous calibration data will be lost. Do not attempt recalibration unless you have appropriate calibration equipment. If calibration data is lost, you will need to return the controller to your supplier who may charge you a service fee to re-calibrate the controller.



 Entering the calibration mode will break the control loop. Make sure that the system is allowable to apply the calibration mode.



### 4.1 Equipment Required Before Calibration

1. A high accuracy calibrator (Fluke 5520A Calibrator recommended) with the following functions
  - ❖ 0 - 100 mV millivolt source with 0.005 % accuracy
  - ❖ 0 - 10 V voltage source with 0.005 % accuracy
  - ❖ 0 - 20 mA current source with 0.005 % accuracy
  - ❖ 0 - 300Ω resistant source with 0.005 % accuracy
2. A test chamber providing 25°C - 50°C temperature range
3. A switching network (SWU16K, optional for automatic calibration)
4. A calibration fixture equipped with programming units (optional for automatic calibration)
5. A PC installed with calibration software (optional for automatic calibration)

The calibration procedures described in the following section are step by step manual procedures. Since a controller needs 30 minutes to warm up before calibration, calibrating the units one by one is quite inefficient. An automatic calibration system for small quantity as well as for an unlimited quantity is available upon request.

#### 4.1.1 Manual Calibration Procedure

Set the Lock parameter to the unlocked condition. Use the   keys to get



 appears on the display. Press  the key to access the calibration password parameter KPAS. Set KPAS to 3418 to enter in to access other calibration parameters.

Press  key to get the parameter **Ad.Lo** and enters into the calibration mode.



##### 4.1.1.1 Calibrate Zero of A to D Converter



Short the thermocouple input terminals, then press  key for at least 5 seconds. The display will blink a moment and a new value is obtained. If the display didn't blink or the obtained value is equal to -199.9 or 199.9, then the calibration failed.

##### 4.1.1.2 Calibrate Gain of A to D Converter

Press  key to get the parameter **Ad.HI** . Send a 60-mV signal to the thermocouple input terminals in correct polarity. Press  key for at least 5 seconds. The display will blink a moment and a new value is obtained. If the display didn't blink or the obtained value is equal to -199.9 or 199.9, then the calibration fails.

##### 4.1.1.3 Calibrate RTD Input

Press  key to get **Rtd.L** Parameter. Send a 100 Ω signal to the RTD input terminals according to the connection. Press  key for at least 5 seconds. The display will blink a moment, otherwise, the calibration failed.

Press  key to get **Rtd.H** Parameter. Change the resistance value to 300Ω. Press  key for at least 5 seconds. The display will blink a moment and two values are obtained for RTDH and RTDL. If the display didn't blink or the obtained value is equal to -199.9 or 199.9, then the calibration failed.

#### 4.1.1.4 Calibrate Offset of Cold Junction Compensation

Setup the equipment according to the following diagram for calibrating the cold junction compensation. Note that a K type thermocouple must be used.

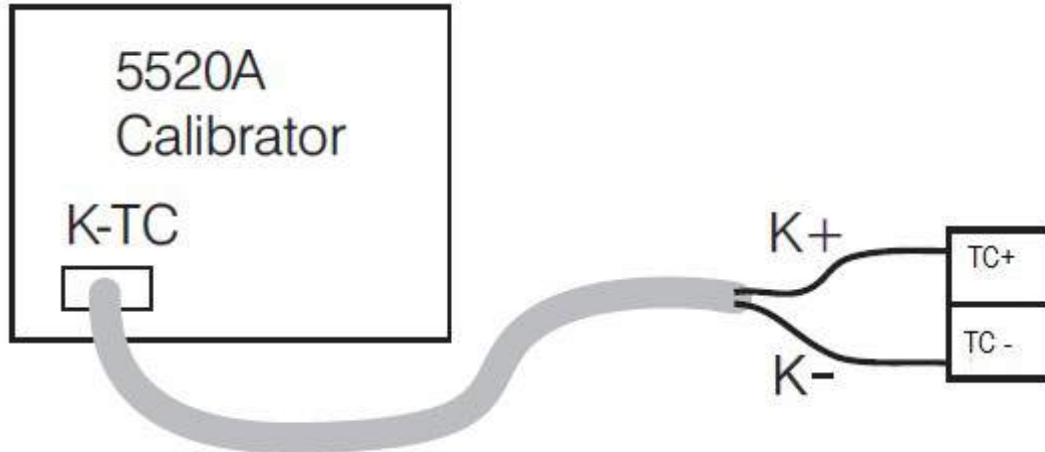



#### 4-1.Cold Junction calibration Setup

Let signal conditioner sit at least 20 minutes in a room temperature of  $25\pm 3^{\circ}\text{C}$ . The 5520A calibrator is to be configured as a K type thermocouple output with internal compensation. Send a  $0.00^{\circ}\text{C}$  signal to the signal conditioner. Perform the steps mentioned above to enter calibration mode, and then press  key to get the parameter **CJ.Lo** Press up/down key to obtaining 40.00. Press the scroll key for at least 5 seconds. The display will blink a moment and a new value is obtained. If the display didn't blink or the obtained value is equal to 5.00 or 40.00, then the calibration failed.



#### 4.1.1.5 Calibrate Gain of Cold Junction Compensation

Setup the equipment the same as during [Offset calibration of Cold Junction Compensation](#). The unit under calibration is to be powered in a room with a temperature of  $50\pm 3^{\circ}\text{C}$  for at least 20 minutes. The calibrator source is to be set to  $0.00^{\circ}\text{C}$  with internal compensation mode.



Perform steps mentioned above to enter calibration mode, and then press  key to get the parameter **CJ.Hi**. Press  key for at least 5 seconds. The display will blink a moment and a new value is obtained. If the display didn't blink or the obtained value is equal to -199.9 or 199.9, then the calibration failed.



This setup is performed in a high-temperature chamber; hence it is recommended to use a computer to perform the procedures

#### 4.1.1.6 Calibrate Linear Input

Press  key and the display will show **V1.L** Send a 0V signal to the V+ and V- terminals. Press  key for at least 5 seconds. The display will blink a moment and a new value is obtained. If the display did not blink or the obtained value is equal -199.9 or 199.9, the calibration failed.



Press  key and the display will show **V1.G** Send a 10V signal to the V+ and V- terminals. Press  key for at least 5 seconds. The display will blink a moment and a new value is obtained. If the display did not blink or the obtained value is equal -199.9 or 199.9, the calibration failed.

Press  key and the display will show **MA1L**. Send a 0mA signal to the mA+ and mA- terminals. Press  key for at least 5 seconds. The display will blink a moment and a new value is obtained. If the display did not blink or the obtained value is equal -199.9 or 199.9, the calibration failed.

Press  key and the display will show **MA1G**. Send a 20mA signal to the mA+ and mA- terminals. Press scroll key for at least 5 seconds. The display will blink a moment and a new value is obtained. If the display did not blink or the obtained value is equal -199.9 or 199.9, the calibration failed.

## 5 Communication

This chapter explains the Modbus Communication protocol of the signal conditioner using RS-485 communication. This supports only RTU mode. Data is transmitted as 8-bit binary bytes with 1 start bit, 1 stop bit and optional parity checking (None, Odd, Even). Baud rate may be set to 2400, 4800, 9600, 14400, 19200, 28800, 38400, 57600 and 115200 BPS.

### 5.1 Functions Supported

Only function code 03, 06 and 16 are available in this signal conditioner. The message formats for each function code are described as follows.

#### 5.1.1 Function Code 03: Read Holding Registers

Query (From Master)	Response (From Slave)
Slave address (1-247)	←
Function code (3)	←
The starting address of register Hi (0)	Byte count
The starting address of register Lo (0-79)	Data1Hi
The starting address of register Lo (128-131)	Data1Lo
No. of words Hi (0)	Data2Hi
No. of words Lo (1-79)	Data2Lo
CRC16Hi	.
CRC16Lo	.
	CRC16Hi
	CRC16Lo

5-1.Function Code 03

#### 5.1.2 Function Code 06: Preset Single Register

Query (From Master)	Response (From Slave)
Slave address (1-247)	←
Function code (6)	←
Register address Hi (0)	←
Register address Lo (0-79, 128-131)	←
Data Hi	←
Data Lo	←
CRC16 Hi	←
CRC16 Lo	←

5-2.Function Code 06

### 5.1.3 Function Code 16: Preset Multiple Register

Query (From Master)	Response (From Slave)
Slave address (1-247)	←
Function code (16)	←
The starting address of register Hi (0)	←
The starting address of register Lo (0-79)	←
The starting address of register Lo (128-131)	←
No. of words Hi (0)	←
No. of words Lo (1-79)	←
Bytes Count (2-158)	CRC16Hi
Data 1 Hi	CRC16Lo
Data 1 Lo	
Data 2 Hi	
Data 2 Lo	
.	
.	
.	
.	
CRC16Hi	
CRC16Lo	

**5-3.Function Code 16**

### 5.2 Exception Responses

If the signal conditioner receives a message which contains a corrupted character (parity check error, framing error etc.), or if the CRC16 check fails, the signal conditioner ignores the message. However, if the signal conditioner receives a syntactically correct message which contains an illegal value, it will send an exception response, consisting of five bytes as follows:

**Slave address +offset function code + exception code + CRC16 Hi +CRC16 Lo**

Where the offset function code is obtained by adding the function code with 128 (i.e. function 3 becomes H'83), and the exception code is equal to the value contained in the following table.

Exception Code	Description	Reason
1	Bad Function Code	The function code is not supported by the controller
2	Illegal Data Addresses	Register address out of range
3	Illegal Data Value	Data value out of range or attempt to write a read-only or protected data

**5-4.Exception Code**

### 5.3 Parameter Mapping

The parameter mapping of Modbus address is available in [section 1.9](#)

### 5.4 Error Code

The description of the Error code is explained below

Error Code	Display Symbol	Description & Reason	Corrective Action
10	ER10	<b>Communication error:</b> bad function code	Correct the communication software to meet the protocol requirements.
11	ER11	<b>Communication error:</b> register address out of range	Do not issue an over-range address of the register to the slave
14	ER14	<b>Communication error:</b> attempt to write a read-only data	Do not write read-only data or protected data to the slave.
15	ER15	<b>Communication error:</b> write a value which is out of range to a register	Do not write an over-range data to the slave register
29	EEPR	EEPROM can't be written correctly	Return to factory for repair.
30	CJER	Cold junction compensation for Thermocouple malfunction	Return to factory for repair.
39	SBER	Input sensor break, or input current below 1 mA if 4-20 mA is used, or input voltage below 0.25V if 1 - 5V is used	Replace the input sensor.
40	AADER	A to D converter or related component(s) malfunction	Return to factory for repair.

#### 5-5.Error Code

### 5.5 Mode

The Value of the Mode Register is as below.

Value	Mode
H'000X	Normal mode
H'010X	Calibration mode
H'030X	Manual control mode
H'040X	Failure mode

#### 5-6.Operation Mode

### 5.6 PROG Code

The Program Code is defined in the below table.

Program Code	Model No
24.XX	R22-SC

#### 5-7.Program Code

## 5.7 Scaling

The scale high/low values are defined in the following table for INLO, INHI, PV, ANL1, ANL2, ANL3, ANH1, ANH2 and ANH3

Condition	Scale Low	Scale High
Non-Linear Input	-1999.9	4553.6
Linear Input DP=0	-19999	45536
Linear Input DP=1	-1999.9	4553.6
Linear Input DP=2	-199.99	455.36
Linear Input DP=3	-19.999	45.536

### 5-8. Scaling for INLO, INHI, PV, ANL1, ANL2, ANL3, ANH1, ANH2 and ANH3

## 5.8 Data Conversion

The word data are regarded as unsigned (positive) Integer data in the Modbus message. However, the actual value of the parameter may be a negative value with the decimal point. The high/low scale values for each parameter are used for the purpose of such conversion.

Let

M = Value of Modbus message

A = Actual value of the parameter

SL = Scale low value of the parameter

SH = Scale high value of the parameter

The conversion formulas are as follows:

$$M = (65535 \div (SH - SL)) * (A - SL)$$

$$A = ((SH - SL) / 65535) * M + SL$$

## 5.9 Communication Examples

### 5.9.1 Read PV, MV1, MV2 and MV3

Send the following command to the controller via the communication port

	03	00	H'32	00	04	HI	LO
Slave Address	Function Code	Starting Address	No of Words		CRC16		

### 5.9.2 Perform Reset Function (same effect as pressing R key)

Query

	06	00	H'48	H'68	H'25	HI	LO
Slave Address	Function Code	Register Address	Data Hi /Lo	CRC16			

### 5.9.3 Enter Auto Tuning Mode

Query

	06	00	H'48	H'68	H'28	HI	LO
Slave Address	Function Code	Register Address	Data Hi /Lo	CRC16			

### 5.9.4 Enter Manual Control Mode

Query

	06	00	H'48	H'68	H'27	HI	LO
Slave Address	Function Code	Register Address	Data Hi /Lo	CRC16			

### 5.9.5 Read All Parameters

Query

	03	00	00	00	H'3E	HI	LO
Slave Address	Function Code	Starting Address	No of Words		CRC16		

### 5.9.6 Modify Calibration Co-efficient

Pre-set the CMND register with 26669 before attempting to change the Calibration coefficient

	06	00	H'48	H'68	H'29	HI	LO
Slave Address	Function Code	Register Address	Data Hi /Lo		CRC16		

## **Attention!!**

The present handbook is merely indicative, and it is subject to changes in any moment, without giving any notice.

The not respecting strictly the indication found on this handbook, the opening and tampering the product, the incorrect use, the wrong wiring, the using of spare parts or optional not original CEAM Control Equipment, the removing of the labels, of the identification marks put by CEAM Control Equipment, and the hidden export to Extra CE countries, they make immediately lose the responsibility over the product and the warranty right.

**WARRANTY TERMS:** the product is under warranty for a period of 12 Months (Art. 1480 C.C. and following) starting by the delivery note date, also in case it is in vision, and then transformed in selling, the complete text of the warranty conditions offered by CEAM Control Equipment in conformity to the actual laws, are published, and are at disposal of any people which demand for them, the document is registered both in paper form and in electronic form, to the CEAM Control Equipment, headquarter, and to see it, it is sufficient to make a written request, specifying the title of the appoint.

### **The warranty cover:**

The products and the components which bad functioning is referable for sure to production defects, the eventual defect met gives only the right to repair it, and not to substitute the product, besides the eventual production defect, does not give any right to resolve the contract, or to suspend the payment if not expressly agreed in written by CEAM.

### **The warranty does not cover:**

Defects generated by incorrect or improper use of the product  
Defects generated by using spare parts or consumables products not original CEAM  
Defects generated by environmental and/or atmospheric problems and/or natural calamity  
Products and/or services tampered or modified even partially  
Products and/or services to which have been taken off, or tampered, even partially, labels and lot codes original CEAM

### **In any case, the warranty does not cover:**

Batteries, magnetic devices, perishable products and/or consumable products  
The components of Third parts, to which it must answer directly, the assistance service of the same, with the modalities provided from them.  
The technical time used to verify and/or to repair the products  
The travelling allowance, and the technical intervention on the place, if effected.  
The packaging and shipping cost of the products there and back.  
All the additional costs supported by CEAM to fulfil the warranty.

### **Clause of responsibility exclusion**

CEAM does not assume any responsibility, regarding eventual damages, direct or in direct, caused to people or things, or damages for ood, production and/or incorrect production and/or eventual damage, in some way referable to the product and/or to this handbook service.

CEAM does not assume any responsibility regarding eventual damages caused to people or things because of the eventual not conformity to the product and/or service of the present handbook, which is merely indicative, and that can be changed by CEAM in any moment without giving any notice.













COMPANY WITH QUALITY SYSTEM CERTIFIED

**ISO**

9001:2015



## **CEAM** Control Equipment srl

Headquarters:

Via Val D'Orme No. 291

50053 Empoli (Firenze) Italy

Tel. (+39) 0571 924082 - Fax. (+39) 0571 924505

Skype Name: [ceam\\_info](#)

### **Internet:**

Group General Web Portal: [www.ceamgroup.com](http://www.ceamgroup.com)

Sector Specific Web: [www.ceamcontrolequipment.it](http://www.ceamcontrolequipment.it)

Technical Support Web: [www.ceamsupport.it](http://www.ceamsupport.it)

### **E-mail service Index:**

General: [info@ceamgroup.it](mailto:info@ceamgroup.it)

Sales Support : [sales@ceamgroup.it](mailto:sales@ceamgroup.it)

### **Area Distributor:**

--